

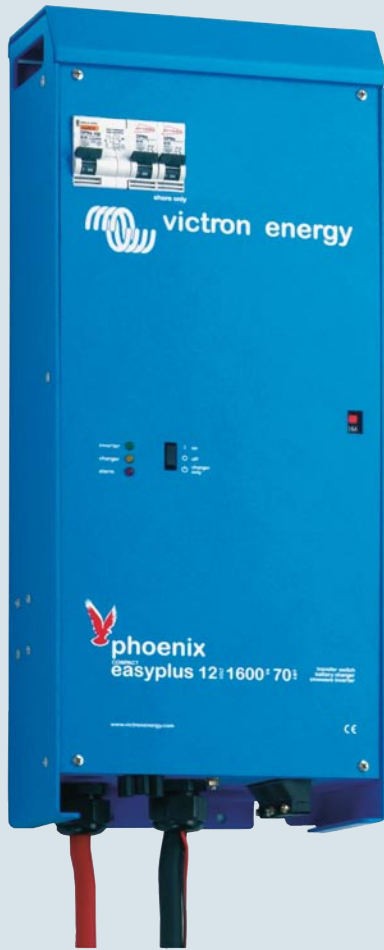

Phoenix EasyPlus

Multi-functional energy system

Phoenix EasyPlus



Multi-functional power solution

The Phoenix EasyPlus is a multifunctional energy system consisting of a powerful sinewave inverter, a sophisticated battery charger, a high speed AC transfer switch and AC distribution in a single light weight and compact enclosure. The system has been designed for those who want to enjoy the comfort and freedom of a complete energy system without spending time on the installation of separate components and difficult technical procedures

Optimum comfort and safety

The EasyPlus guarantees uninterrupted power supply, whenever and wherever you are. Where shore or generator power is limited, the unique PowerAssist[®] technology makes it possible to boost the total capacity by adding extra energy from the batteries. Optimum safety is guaranteed with the integrated RCD (Residual Current Device) protecting against earth leakage.

5 step installation: quick and easy

The EasyPlus gets its name from the simplicity of installation and use. The system can be installed within five simple steps making significant savings in time as well as space. The Easy Plus provides plugs and sockets for all AC connections and is supplied with the battery cables already fitted so you can save hours in installation time.

Step 1. Select a suitable place for the EasyPlus (as close as possible to the batteries) and install the wall mounting bracket. Attach the Easy Plus to the bracket and secure it with the screws provided.

Step 2. Connect the shore/generator input power and the outgoing circuits (including dedicated water heater feed) to the Easy Plus.

Step 3. Connect the control panel with the UTP patch lead (both supplied as standard).

Step 4. Connect the battery cables and temperature sensor to the batteries (also supplied as standard).

Step 5. Switch on the RCD, the AC distribution and the inverter charger and the system is ready to use.

How does it work?

The Phoenix EasyPlus is connected to the batteries and to the shore power or generator. The maximum available generator or shore current is set using the dial on the control panel. The output consumers are divided into two groups. The first group consists of the 'regular', low or short term power users such as sockets or kitchen equipment. This group can be fed from both shore/generator and battery power via the inverter. The second group is the 'heavy user' circuit. This can be a water heater or the air-conditioning. In order to protect the batteries from excessive discharge, this group is shore/generator-only and cannot be supplied when the inverter is functioning. Unique **PowerAssist[®]** technology protects the shore or generator from being overloaded by adding extra inverter power when needed.



Technical information

- 12 Volt 1600VA sine wave inverter (3000 Watt peak power)
- 70A charger incl. 4A trickle charge for start battery
- Unique **PowerAssist**® technology protects the shore or generator from being overloaded by adding extra inverter power when needed
- 4 stage adaptive charge technology for quick and accurate battery charging
- RCD (30mA/16A) on AC output
- Two AC output sockets protected by 16A automatic circuit breakers for optimum safety
- Second AC output active only when shore power is available
- No-break system: uninterrupted switching between shore/generator and inverter
- Battery cables and remote panel included
- 24 Month worldwide warranty

Dimensions

Height : 510 mm
 Width : 214 mm
 Depth : 110 mm
 Weight : 11,7 Kg



Typical installation and Wiring Diagram

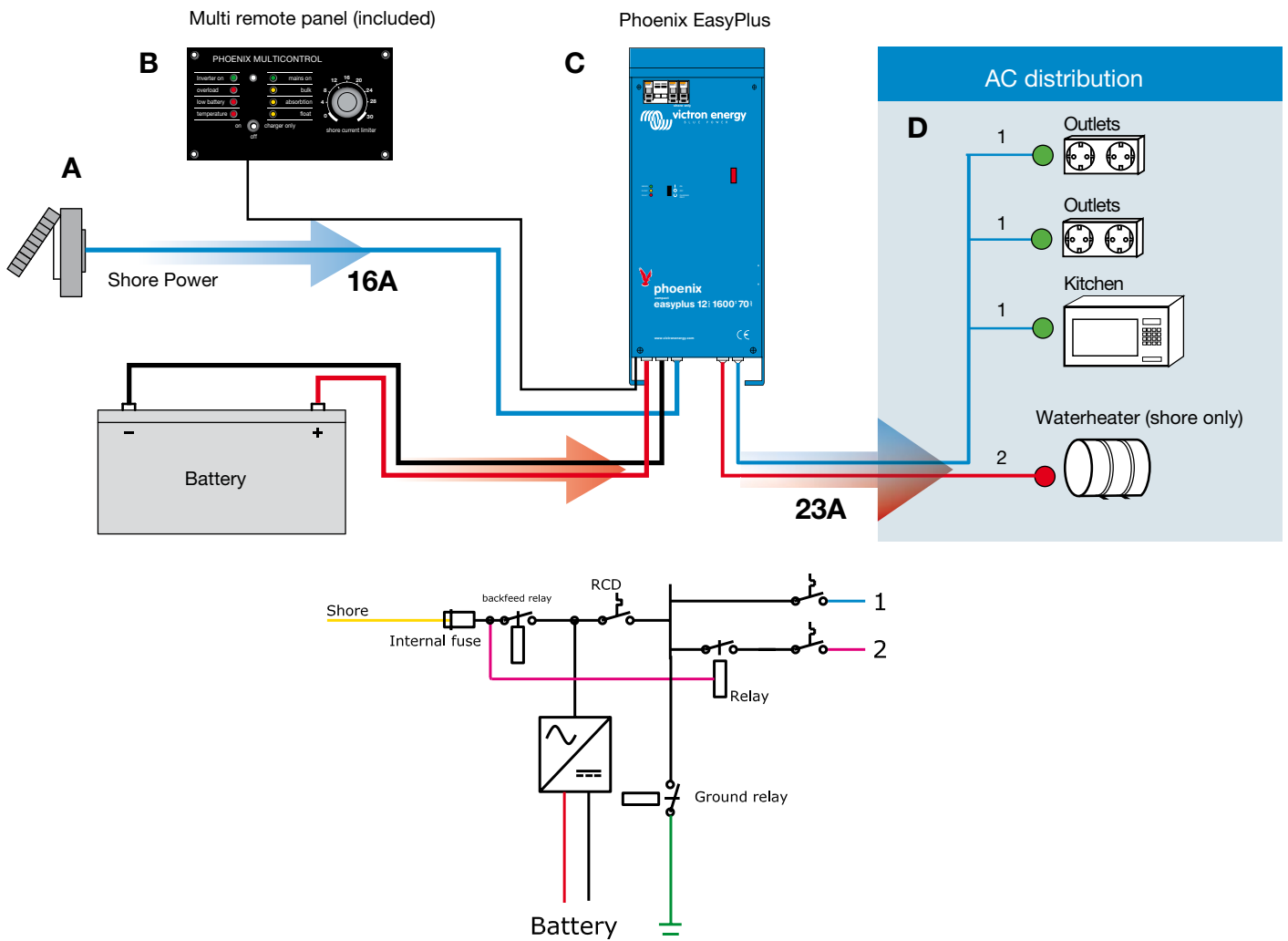



**Victron Energy B.V. / De Paal 35
1351 JG Almere / The Netherlands**

**Phone: +31 (0)36 535 97 00
Fax: +31 (0)36 535 97 40
e-mail: sales@victronenergy.com**

www.victronenergy.com

