



# victron energy

B L U E P O W E R

Quattro 5kVA

## Quattro 5 kVA 120/240V series Inverter/Charger

### Two AC inputs with integrated transfer switch

The Quattro can be connected to two independent AC sources, for example shore-side (grid-) power and a generator, or two generators. The Quattro will automatically connect to the active source.

### 120/240 V input and output

The two AC inputs can be supplied from a split phase (up to 60 A per phase), dual AC (up to 60 A total), or single phase AC (up to 50 A) source. The AC inputs can be connected to a different type of supply: one input may for example be connected to a split phase source, and the other to a single phase source.

When an AC source is available, the Quattro will feed through the AC to its output. The output will therefore mirror the AC input.

The inverter/charger connects to the neutral and the preferred input line (L1). Power needed to charge the batteries will therefore be drawn from L1.

The Quattro switches to inverter operation when no AC source is available. The inverter output is 120 V single phase. In Invert mode, the Quattro connects both output lines (L1 and L2) together to provide 120 VAC to loads on either line. Any 240 VAC loads will therefore be supplied only when the Quattro is supplied by a split phase AC source. This prevents heavy loads such as water heaters or 240 V air conditioners from discharging the battery.

The Quattro provides seamless transfer (no-break functionality) on output L1. Output L2 connects to the inverter after a short delay.

### PowerControl - Dealing with limited generator, shore-side or grid power

The Quattro is a very powerful battery charger. It will therefore draw a lot of current from the generator or shore side supply (34 A per Quattro at 120 VAC). A current limit can be set for L1 on both AC inputs. The Quattro will then take account of other AC loads and use whatever is spare for charging, thus preventing the generator or shore supply from being overloaded.

### PowerAssist - Boosting shore or generator power

This feature takes the principle of PowerControl to a further dimension allowing the Quattro to supplement the capacity of the alternative source. Where peak power is so often required only for a limited period, the Quattro will make sure that insufficient shore or generator power is immediately compensated for by power from the battery (L1 inputs only). When the load reduces, the spare power is used to recharge the battery.

### Virtually unlimited power thanks to parallel operation

Up to 6 Quattro's can operate in parallel. Six units 24/5000/120, for example, will provide 25kW / 30kVA output power and 720 Amps charging capacity.

### Three phase and split phase capability

Three resp. two units can be configured for three-phase resp. split phase output. But that's not all: up to 6 units can be paralleled per phase (max 18 units in a three phase system and max. 12 units in a split phase system).

### Solar energy: AC power available even during a grid failure

The Quattro can be used both in off-grid and on-grid connected PV, and in other alternative energy systems.

### A grid connected PV system will shut down when the grid fails! Not anymore with a Quattro and batteries

A PV or other grid connected alternative energy system is a big investment. But it is incomplete: it will shut down in the event of a grid failure. A Quattro plus battery can solve this deficiency: the Quattro will replace the grid when needed, keeping the alternative energy system 'on line'. During a power outage the system continues to function 'on its own', as a small autonomous grid. The Quattro will stabilise the 'mini grid' by taking power from it to recharge the battery when power generation exceeds consumption, and by supplying additional power when demand exceeds the supply from the alternate sources. In addition, the Quattro can be used to connect an AC generator to the mini grid.

### System configuring has never been easier

After installation, the Quattro is ready to go.

If settings have to be changed, this can be done in a matter of minutes with a new DIP switch setting procedure.

Even parallel and 3-phase operation can be programmed with DIP switches: no computer needed!

Alternatively, VE.Net can be used instead of the DIP switches.

And sophisticated software (VE.Bus Quick Configure and VE.Bus System Configurator) is available to configure several new, advanced, features.

Victron Energy B.V. / De Paal 35 / 1351 JG ALMERE / The Netherlands

Phone: (+31) (0)36 535 97 00 / Fax: (+31) (0)36 535 97 40 / [www.victronenergy.com](http://www.victronenergy.com) / e-mail: [sales@victronenergy.com](mailto:sales@victronenergy.com)





# Quattro 5kVA

## Specifications

Quattro	12/5000/200 120/240V	24/5000/120 120/240V	48/5000/70 120/240V
PowerControl / PowerAssist	Yes	Yes	Yes
Integrated Transfer switch	Yes	Yes	Yes
AC inputs (2x)	Input voltage: 120 V or 120/240 V		Input frequency: 45 – 65 Hz Power factor: 1
AC feed through capacity (A)	120V single phase: 60 A 120V dual in phase: 60 A total 120/240 V split phase: 60 A each leg		
<b>INVERTER</b>			
Input voltage range (V DC)	9,5 – 17	19 – 33	38 – 66
Output (pure sinewave)	Output voltage: 120 VAC ± 2%		Frequency: 60 Hz ± 0,1% (1)
Cont. output power at 77°F/25°C (VA) (5)	5000	5000	5000
Cont. output power at 77°F/25°C (W)	4000	4250	4250
Cont. output power at 100°F/40°C (W)	3000	3350	3350
Peak power (W)	8000	10.000	10.000
Maximum efficiency (%)	92	94	95
Zero-load power (W)	25	30	30
Load shedding output	When unit is running in inverter mode, all 240V applications are switched off		
<b>CHARGER</b>			
Charge voltage 'absorption' (V DC)	14,4	28,8	57,6
Charge voltage 'float' (V DC)	13,8	27,6	55,2
Storage mode (V DC)	13,2	26,4	52,8
Charge current house battery (A) (4)	200	120	70
Charge current starter battery (A)	4		
Battery temperature sensor	Yes		
<b>GENERAL</b>			
Multi purpose relay (6)	Yes	Yes	Yes
Protection (2)	a – f		
Common Characteristics	Operating temp.: 0 to 120°F (-20 to +50°C) Humidity (non condensing) : max 95%		
<b>ENCLOSURE</b>			
Common Characteristics	Material & Colour: aluminium (blue RAL 5012)	Protection category: IP 21	
Battery-connection	Four M8 bolts (2 plus and 2 minus connections)		
120/240 V AC-connection	Screw clamp 13mm <sup>2</sup> (AWG 6)		
Weight	66 lb	30 kg	
Dimensions (hwxwd)	17,5 x 13,0 x 9,6 inch	444 x 328 x 240 mm	
<b>STANDARDS</b>			
Safety	EN 60335-1, EN 60335-2-29		
Emission / Immunity	EN55014-1, EN 61000-3-2 / EN 55014-2, EN 61000-3-3		

1) Can be adjusted to 50 Hz

2) Protection

- Output short circuit
- Overload
- Battery voltage too high
- Battery voltage too low
- 120VAC on inverter output
- Input voltage ripple too high

3) Suitable for parallel, split-phase and 3-phase operation

4) At 25 °C ambient

5) Non linear load, crest factor 3:1

6) Multipurpose relay which can be set for general alarm, DC undervoltage or genset start signal function

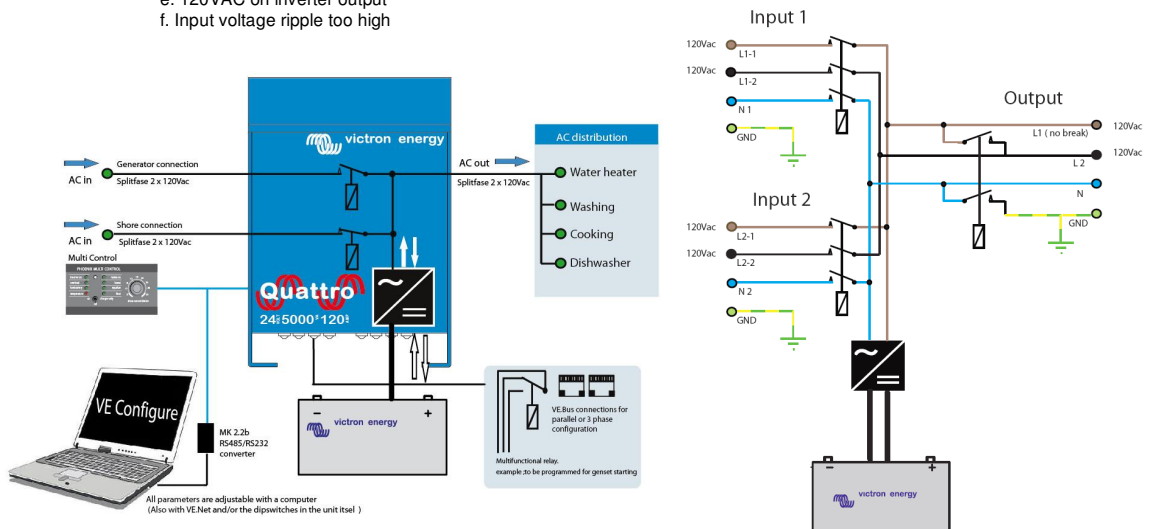

Victron Energy B.V. / De Paal 35 / 1351 JG ALMERE / The Netherlands

Phone: (+31) (0)36 535 97 00 / Fax: (+31) (0)36 535 97 40 / [www.victronenergy.com](http://www.victronenergy.com) / e-mail: [sales@victronenergy.com](mailto:sales@victronenergy.com)